

GARAGE/SHOP SERIES **MHT45 LOW INTENSITY** **INFRARED TUBE HEATER**



Model MHT45
45,000 BTU/HR Heater For:

- Residential Garages
- Small Shops
- Restaurant Decks & Patios
- Entrance Ways
- Golf Driving Ranges
- Farm Buildings
- Bus & Smoking Shelters
- Green Houses

America's Most Complete Lineup Of Infrared Heaters.

EFFICIENT AND EFFECTIVE LOW-INTENSITY INFRARED RADIANT HEAT.

- Provides Uniform Heat Distribution
- Compact – 3" Aluminized Steel U-Tube Design
- Polished Aluminum Deep-Dish Reflector
- Burner And Tube/Reflector Assembly Shipped In Separate Cartons To Eliminate Shipping Damage

Easy Installation

- Simply:
 1. Hang Burner/Tube/Reflector Assembly
 2. Run Gas, Electric And Vent
- Horizontal Or Angle Mount
- 10' Overall Length
- Air Intake And Exhaust Collars Attached
- Total Weight: 91 lbs.

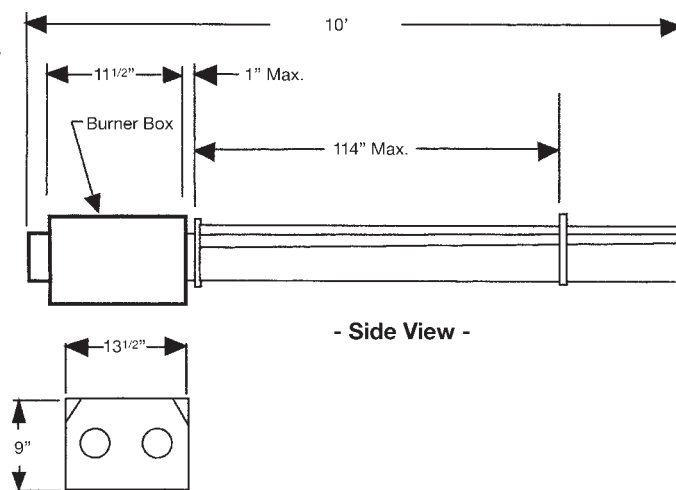

Operating Flexibility

- Commercial And Residential Approved
- Indoor And Outdoor Approved
- Limited 3-Year Warranty

Accessories

- Optional Vent Kit (Horizontal/Vertical)
Stock No. F102840 (3" DIA.)
- Optional 24-Volt Thermostat
Stock No. 10371

TECHNICAL DATA	MHT45NG	MHT45LP
Stock Number	F208850	F208851
Input (BTU/HR)*	45,000	45,000
Electrical Rating	120VAC, 60Hz, single phase, 1 amp	120VAC, 60Hz, single phase, 1 amp
Electrical Connection	3 pin moulded plug	3 pin moulded plug
Gas Inlet Connection	1/2" male NPT	1/2" male NPT
Gas Inlet Pressure		
MINIMUM	5.0" w.c.	11.0" w.c.
MAXIMUM	10.5" w.c.	13.5" w.c.
Manifold Pressure	4.0" w.c.	10.0" w.c.
Weight	91 lbs.	91 lbs.
Length	10'	10'

MOUNTING CLEARANCES		
	HORIZONTAL	45° ANGLE
Top	5"	5"
Bottom	54"	36"
Reflector Side	24"	4"
Tube Side	24"	38"
Reflector End	6"	6"
Burner End	24"	24"

VENTING SPECIFICATIONS	
Length	5 feet
MINIMUM	5 feet
MAXIMUM	25 feet
Flue Pipe	3.0" diameter
Vent Pipe	3.0" diameter



CSA Certified

* Ratings shown are for elevations up to 2,000 feet. (In Canada, refer to rating tag.) For elevations above 2,000 feet, ratings should be reduced at the rate of 4% for each 1,000 feet above sea level or as specified by local authority having jurisdiction.