

patioSchwank TECH SPECS



SERIES 1100

MODEL NO.	BTU/Hr	GAS	MINIMUM GAS LINE PRESSURE	MAXIMUM GAS LINE PRESSURE	MANIFOLD PRESSURE	DIMENSION LxH	WEIGHT IN LBS.
1110-N	29,500	NG	6" W.C.	14" W.C.	5" W.C.	39 1/4" X 21 1/4"	72
1110-L	29,500	LP	11" W.C.	14" W.C.	10" W.C.	39 1/4" X 21 1/4"	72
1115-N	44,000	NG	6" W.C.	14" W.C.	5" W.C.	50 1/2" x 21 1/4"	88
1115-L	44,000	LP	11" W.C.	14" W.C.	10" W.C.	50 1/2" x 21 1/4"	88

ELECTRICAL			GAS INLET SIZE
24VOLT	60 HERTZ	120 VA	1/2"

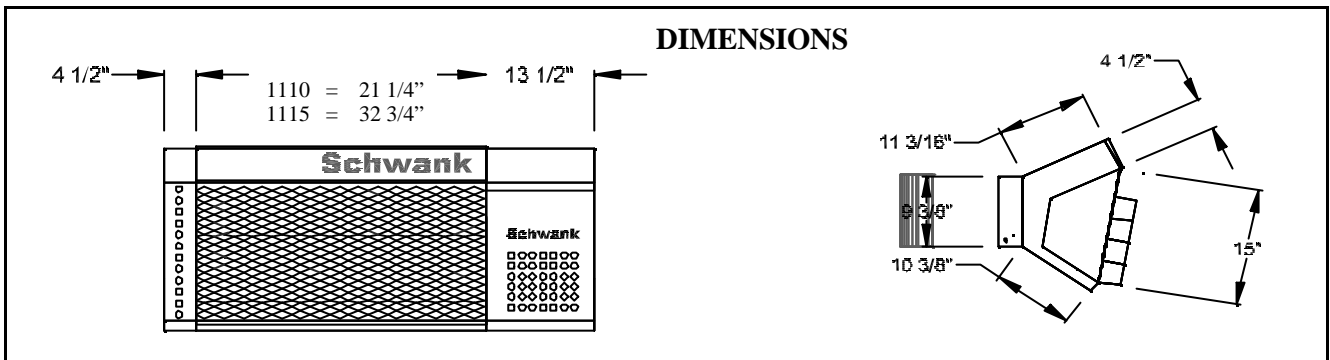

MINIMUM CLEARANCES TO COMBUSTIBLES:

MODEL	Front and rear of heater < F >	Below heater < G >	Front and rear of heater < F >
1110	30"	90"	66"
1115	30"	96"	66"

